



4.1 Electrical and Technical Tapes

Vinyl Electrical Tapes		
All Purpose Electrical Tape	HelaTape Flex 15	454
	HelaTape Flex 20	456
For Higher Mechanical Requirements	HelaTape Flex 25	457
Premium Electrical Tape	HelaTape Flex 1000+	458
Premium Heavy Duty Electrical Tape	HelaTape Flex 2000+	459
Corrosion Protection Tape	HelaTape Wrap 25	460
Conductive Tapes		
Electrical Semi-Conducting Tape	HelaTape Shield 310	461
Self-amalgamating Tapes		
Low Voltage Rubber Tape	HelaTape Power 600	462
Electrical Insulation Mastic	HelaTape Power 650	463
Rubber Mastic Tape	HelaTape Power 660 RM	464
Vinyl Mastic Tape	HelaTape Power 670 VM	465
Silicone Rubber Tape	HelaTape Power 800	466
	HelaTape Power 810	467
High Voltage Rubber Tape	HelaTape Power 820 (Linerless)	468

Technical Tapes

Vinyl Bundling Tape	HelaTape Allround 1500	469
Cloth Tape	HelaTape Tex	470

Wire Harness Tapes

Hand-tearable Cloth Tape	Protect 180	471
Strong, High Temperature Cloth Tape	Protect 250	472
Soft and Flexible Fleece Tape	Protect 300	473



4.2 Wire Connectors

Connectors		
For all Types of Wire	HelaCon Plus Releasable	474
HelaCon-Series	HelaCon Plus Mini	475
For Lighting Installation	HelaCon Lux	477



4.3 Cable Rods

Cable Installation System

	Cable Scout+ Sets	478
Cable Rod System	Cable Scout+ Pairs	479
	Cable Scout+ Accessories	480



4.4 Downlight Covers

Downlight covers

	SpotClip-I	481
	SpotClip-II	482
Downlight Covers - For Residential Buildings	SpotClip-III	484
	SpotClip-IV-Slim	486
	SpotClip-Box	487
	SpotClip-Kit	489
Downlight Covers - For Industrial Buildings	SpotClip-Plate	491
	SpotClip-Caps	492



4.5 Cable Entry Systems

VarioPlate Cable Entry System

VarioPlate Frames	493
VarioPlate Insert Grommets	494
VarioPlate Blindplugs	496
VarioPlate Mounting Tool	497



4.6 Connection Products

Nylon Cable Glands

	498
--	-----



Vinyl Electrical Tapes – Commercial Grade Vinyl Electrical Tape

HelaTape Flex 15

Primary electrical insulation for all wire and cable splices up to 1 kV.
Protective jacketing for low, medium and high voltage splices.
Wrapping of wire harnesses and cables.
Used for indoor and outdoor applications.

Features and benefits

- Vinyl electrical tape in many different colours
- Used for insulation, protection, fixing, maintenance, colour coding and more
- Good resistance to abrasion, sunlight, moisture, chemicals and varying weather conditions
- Highly flexible with outstanding adhesion performance
- Harnessing of wires and cables
- Suitable for mechanical and electrical applications up to 1 kV
- VDE approved according to IEC 60454-3-1-6/F-PVCP/90
- Flame retardant according to IEC 60454-2



HelaTape Flex 15 – Vinyl Electrical Tapes.

MATERIAL	Polyvinylchloride (PVC)
Dielectric Strength	45 kV/mm
Adhesion to Steel	2.2 N/10 mm
Adhesion to Backing	2.0 N/10 mm
Elongation at break (min.)	200 %
Breaking Strength	28 N/10 mm
Operating Temperature	-10 °C to +90 °C

RoHS

TYPE	Thickness (T)	Width (W)	Length (L)	Colour	Article-No.
HTAPE-FLEX15-15x10	0.15	15.0	10.0 m	Black (BK)	710-00104
	0.15	15.0	10.0 m	Blue (BU)	710-00100
	0.15	15.0	10.0 m	Brown (BN)	710-00107
	0.15	15.0	10.0 m	Green (GN)	710-00103
	0.15	15.0	10.0 m	Green-Yellow (GNYE)	710-00106
	0.15	15.0	10.0 m	Grey (GY)	710-00108
	0.15	15.0	10.0 m	Orange (OG)	710-00110
	0.15	15.0	10.0 m	Red (RD)	710-00101
	0.15	15.0	10.0 m	Red (RD), Grey (GY), Yellow (YE), Green (GN), Blue (BU), Orange (OG), White (WH), Brown (BN), Black (BK), Green-Yellow (GNYE)	710-00146
	0.15	15.0	10.0 m	Transparent (CL)	710-00147
	0.15	15.0	10.0 m	Violet (VT)	710-00109
	0.15	15.0	10.0 m	White (WH)	710-00105
	0.15	15.0	10.0 m	Yellow (YE)	710-00102
HTAPE-FLEX15-15x25	0.15	15.0	25.0 m	Black (BK)	710-00115

All dimensions in mm. Subject to technical changes. Minimum Order Quantity (MOQ) may differ from package content.



Please note: Some or all of the products listed here have these approvals, or have one or more sustainable attributes. Please see our website for the latest details.



Vinyl Electrical Tapes – Commercial Grade Vinyl Electrical Tape

HelaTape Flex 15

TYPE	Thickness (T)	Width (W)	Length (L)	Colour	Article-No.
HTAPE-FLEX15-19x20	0.15	19.0	20.0 m	Black (BK)	710-00155
	0.15	19.0	20.0 m	Blue (BU)	710-00151
	0.15	19.0	20.0 m	Brown (BN)	710-00158
	0.15	19.0	20.0 m	Green (GN)	710-00154
	0.15	19.0	20.0 m	Green-Yellow (GNYE)	710-00157
	0.15	19.0	20.0 m	Grey (GY)	710-00159
	0.15	19.0	20.0 m	Red (RD)	710-00152
	0.15	19.0	20.0 m	Violet (VT)	710-00160
	0.15	19.0	20.0 m	White (WH)	710-00156
	0.15	19.0	20.0 m	Yellow (YE)	710-00153
HTAPE-FLEX15-19x25	0.15	19.0	25.0 m	Black (BK)	710-00126
HTAPE-FLEX15-25x25	0.15	25.0	25.0 m	Black (BK)	710-00137
	0.15	25.0	25.0 m	Blue (BU)	710-00133
	0.15	25.0	25.0 m	Brown (BN)	710-00140
	0.15	25.0	25.0 m	Green (GN)	710-00136
	0.15	25.0	25.0 m	Green-Yellow (GNYE)	710-00139
	0.15	25.0	25.0 m	Grey (GY)	710-00141
	0.15	25.0	25.0 m	Red (RD)	710-00134
	0.15	25.0	25.0 m	White (WH)	710-00138
0.15	25.0	25.0 m	Yellow (YE)	710-00135	

All dimensions in mm. Subject to technical changes. Minimum Order Quantity (MOQ) may differ from package content.



Please note: Some or all of the products listed here have these approvals, or have one or more sustainable attributes. Please see our website for the latest details.



Vinyl Electrical Tapes – Insulating Tape for Higher Mechanical Requirements

HelaTape Flex 20

Primary electrical insulation for all wire and cable splices up to 1 kV.
Protective jacketing for low, medium and high voltage splices.
Wrapping of wire harnesses and cables.
Used for indoor and outdoor applications.

Features and benefits

- Vinyl electrical tape with strong rubber adhesive
- Suitable for mechanical and electrical applications up to 1 kV
- Additional thickness for quicker layering and higher abrasion resistance
- Weather resistant
- Flame retardant according to UL 510 Standard



HelaTape Flex 20 - Additional thickness allows for quicker layering.

MATERIAL	Polyvinylchloride (PVC)
Dielectric Strength	40 kV/mm
Adhesion to Steel	2.5 N/10 mm
Adhesion to Backing	2.5 N/10 mm
Elongation at break (min.)	240 %
Breaking Strength	40 N/10 mm
Operating Temperature	-10 °C to +105 °C

RoHS

TYPE	Thickness (T)	Width (W)	Length (L)	Colour	Article-No.
HTAPE-FLEX20-19x20	0.20	19.0	20.0 m	Black (BK)	710-10300

All dimensions in mm. Subject to technical changes. Minimum Order Quantity (MOQ) may differ from package content.



Please note: Some or all of the products listed here have these approvals, or have one or more sustainable attributes. Please see our website for the latest details.



Vinyl Electrical Tapes – Insulating Tape for Higher Mechanical Requirements

HelaTape Flex 25

Primary electrical insulation for all wire and cable splices up to 1 kV.
 Protective jacketing for low, medium and high voltage splices.
 Wrapping of wire harnesses and cables.
 Used for indoor and outdoor applications.

Features and benefits

- Vinyl film coated with high quality rubber adhesive
- Extra high material thickness
- Highly resistant to sun, water, oil, acids, alkalies, corrosive chemicals
- Used for insulation, protection, fixing, maintenance and more
- Superior vinyl tape with excellent all-weather performance
- Flame retardant according to UL 510 Standard



HelaTape Flex 25 for higher abrasion resistance.

MATERIAL	Polyvinylchloride (PVC)
Dielectric Strength	45 kV/mm
Adhesion to Steel	2.6 N/10 mm
Adhesion to Backing	2.6 N/10 mm
Elongation at break (min.)	240 %
Breaking Strength	46 N/10 mm
Operating Temperature	-10 °C to +90 °C



TYPE	Thickness (T)	Width (W)	Length (L)	Colour	Article-No.
HTAPE-FLEX25-19x33	0.25	19.0	33.0 m	Black (BK)	710-00450
HTAPE-FLEX25-38x33	0.25	38.0	33.0 m	Black (BK)	710-00451

All dimensions in mm. Subject to technical changes. Minimum Order Quantity (MOQ) may differ from package content.



Vinyl Electrical Tapes – Premium Vinyl Electrical Tape

HelaTape Flex 1000+

Primary electrical insulation for all wire and cable splices up to 1 kV.
Protective jacketing for low, high and medium voltage splices.
Harnessing of wires and cables.
Used for indoor and outdoor applications.

Features and benefits

- All-weather highly flexible, professional grade, self-adhesive vinyl electrical tape
- Excellent performance and durability over wide temperature range from -18°C to +105°C according to CSA C22.2
- VDE approved according to IEC 60454-3-1-7/F-PVCP/90
- Used for insulation, protection, fixing, maintenance, colour coding
- Pressure sensitive high quality rubber based adhesive
- Excellent resistance to abrasion, moisture, chemicals, corrosion and UV exposure
- Primary electrical insulation for all wire and cable splices up to 1 kV
- Protective jacketing for low, medium and high voltage splices and repairs
- Flame retardant according to UL 510 Standard
- For indoor and outdoor applications
- Size 19 mm x 20 m is single packed in a plastic can only
710-10601 comes in a pack of 10 pcs



HelaTape Flex 1000+ provides excellent low temperature performance.

MATERIAL	Polyvinylchloride (PVC)
Dielectric Strength	45 kV/mm
Adhesion to Steel	3.0 N/10 mm
Adhesion to Backing	2.7 N/10 mm
Elongation at break (min.)	300 %
Breaking Strength	35 N/10 mm
Operating Temperature	-18 °C to +105 °C

RoHS

TYPE	Thickness (T)	Width (W)	Length (L)	Colour	Article-No.
HTAPE-FLEX1000+ 19x6	0.18	19.0	6.0 m	Black (BK)	710-10600
HTAPE-FLEX1000+ C 19x20	0.18	19.0	20.0 m	Black (BK)	710-10602
HTAPE-FLEX1000+ 19x20 PACK	0.18	19.0	20.0 m	Black (BK)	710-10601
HTAPE-FLEX1000+ C 19x20	0.18	19.0	20.0 m	Blue (BU)	710-10603
	0.18	19.0	20.0 m	Brown (BN)	710-10608
	0.18	19.0	20.0 m	Green (GN)	710-10606
	0.18	19.0	20.0 m	Green-Yellow (GNYE)	710-10612
	0.18	19.0	20.0 m	Grey (GY)	710-10609
	0.18	19.0	20.0 m	Red (RD)	710-10604
	0.18	19.0	20.0 m	White (WH)	710-10607
	0.18	19.0	20.0 m	Yellow (YE)	710-10605
HTAPE-FLEX1000+ 19x33	0.18	19.0	33.0 m	Black (BK)	710-10610
HTAPE-FLEX1000+ 50x33	0.18	50.0	33.0 m	Black (BK)	710-10611

All dimensions in mm. Subject to technical changes. Minimum Order Quantity (MOQ) may differ from package content.



Please note: Some or all of the products listed here have these approvals, or have one or more sustainable attributes. Please see our website for the latest details.



Vinyl Electrical Tapes – Premium Heavy Duty Vinyl Electrical Tape

HelaTape Flex 2000+

Primary electrical insulation for all wire and cable splices up to 1 kV.
Protective jacketing for low, high, and medium voltage splices.
Harnessing of wires and cables.
Used for indoor and outdoor applications.

Features and benefits

- All-weather, highly flexible, professional grade, self-adhesive vinyl electrical tape with higher thickness for more mechanical and electrical protection
- Excellent performance and durability over wide temperature range from -18 °C to +105 °C according to CSA C22.2
- Pressure sensitive and aggressive high quality rubber based adhesive
- Performs continuously at low temperature environment
- Flame retardant according to UL 510 Standard
- Excellent resistance to abrasion, moisture, chemicals, corrosion and UV exposure
- Primary electrical insulation for all wire and cable splices up to 1 kV



HelaTape Flex 2000+ is the best choice for professional installation.

MATERIAL	Polyvinylchloride (PVC)
Dielectric Strength	40 kV/mm
Adhesion to Steel	3.0 N/10 mm
Adhesion to Backing	2.4 N/10 mm
Elongation at break (min.)	300 %
Breaking Strength	40 N/10 mm
Operating Temperature	-18 °C to +105 °C

RoHS ✓

TYPE	Thickness (T)	Width (W)	Length (L)	Colour	Article-No.
HTAPE-FLEX2000+19x20	0.21	19.0	20.0 m	Black (BK)	710-10701
HTAPE-FLEX2000+38x20	0.21	38.0	20.0 m	Black (BK)	710-10705

All dimensions in mm. Subject to technical changes. Minimum Order Quantity (MOQ) may differ from package content.



Please note: Some or all of the products listed here have these approvals, or have one or more sustainable attributes. Please see our website for the latest details.



Vinyl Electrical Tapes – Vinyl Tape for Corrosion Protection

HelaTape Wrap 25

This is a PVC tape with a special adhesive. This tape offers an excellent protection against corrosion and gives complete environmental, mechanical and electrical protection for all types of pipe wrapping applications. It is also resistant to UV, bacteria and fungus. HelaTape Wrap can be used for outside and underground applications.

Features and benefits

- Special adhesive with excellent protection against corrosion
- Complete environmental, mechanical and electrical protection
- Highly resistant to UV, water, oil, most chemicals, bacteria and fungus
- Used for pipes, tubes, and conduits in outside and underground applications



HelaTape Wrap 25 protects against all types of corrosion.

MATERIAL	Polyvinylchloride (PVC)
Dielectric Strength	40 kV/mm
Adhesion to Steel	2.2 N/10 mm
Adhesion to Backing	2.0 N/10 mm
Elongation at break (min.)	200 %
Breaking Strength	44 N/10 mm
Operating Temperature	-10 °C to +90 °C

RoHS ✓

TYPE	Thickness (T)	Width (W)	Length (L)	Colour	Article-No.
HTAPE-WRAP25-25x30	0.25	25.0	30.0 m	Black (BK)	710-10800
HTAPE-WRAP25-50x30	0.25	50.0	30.0 m	Black (BK)	710-10802
HTAPE-WRAP25-100x30	0.25	100.0	30.0 m	Black (BK)	710-10803

All dimensions in mm. Subject to technical changes. Minimum Order Quantity (MOQ) may differ from package content.



Please note: Some or all of the products listed here have these approvals, or have one or more sustainable attributes. Please see our website for the latest details.



Conductive Tapes – Electrical Semi-Conducting Tape

HelaTape Shield 310

Features and benefits

- Self-amalgamating conducting tape made from ethylene propylene rubber
- Provides good conducting properties
- Prevents partial discharges
- Moisture and UV-resistant and easy to apply
- Guidance and/or finishing of the semiconductive layer in case of repairs and connections of medium to high voltage cables.



HelaTape Shield 310 self-amalgamating conducting tape for shielding high-voltage splices and terminations.

MATERIAL	Ethylene Propylene Rubber (EPR)
Operating Temperature	-40 °C to +90 °C
Intermittent Operating Temperature	+130 °C
Water Absorption	0.02 %
Tensile Strength	2.0 MPa
Elongation at break (min.)	600 %
Volume Resistance	870 Ω cm



TYPE	Thickness (T)	Width (W)	Length (L)	Colour	Article-No.
HTAPE-SHIELD310	0.76	19.0	4.6 m	Black (BK)	711-10000
	0.76	38.0	9.1 m	Black (BK)	711-10001

All dimensions in mm. Subject to technical changes. Minimum Order Quantity (MOQ) may differ from package content.



Self-amalgamating Tapes – Low Voltage Rubber Tape

HelaTape Power 600

HellermannTyton offers a wide range of products for bundling, insulating, sealing and labeling cables and wires. PVC insulation tapes for low-voltage applications are available in various colors and dimensions. Self-welding, rubber-based tapes are ideal for insulating and sealing cables and connections from low to high and extra-high voltage ranges. HelaTape Tex fabric tapes are versatile and easy to write on.

Features and benefits

- Self-amalgamating low voltage rubber tape
- Primary insulation at not more than 1 kV
- Easily suitable to irregular shapes and surfaces
- Compatible with all extruded dielectric cable insulations
- Weather resistant and flame retardant according to UL 510
- Excellent for repairing e.g. damaged cable sheaths against moisture ingress, where finishing with some layers of HelaTape Flex will do the mechanical protection.



HelaTape Power 600 is a self-amalgamating low-voltage rubber tape.

MATERIAL	Natural Rubber (NR)
Operating Temperature	-40 °C to +80 °C
Intermittent Operating Temperature	+95 °C
Tensile Strength	2 N/mm ²
Elongation at break (min.)	300 %
Dielectric Strength	14 kV/mm



TYPE	Thickness (T)	Width (W)	Length (L)	Colour	Article-No.
HTAPE-POWER600-19x6.7	0.76	19.0	6.7 m	Black (BK)	711-10200
HTAPE-POWER600-38x6.7	0.76	38.0	6.7 m	Black (BK)	711-10201

All dimensions in mm. Subject to technical changes. Minimum Order Quantity (MOQ) may differ from package content.



Self-amalgamating Tapes – Electrical Insulation Mastic

Helatape Power 650

HellermannTyton offers a wide range of products for bundling, insulating, sealing and labeling cables and wires. PVC insulation tapes for low-voltage applications are available in various colors and dimensions. Self-welding, rubber-based tapes are ideal for insulating and sealing cables and connections from low to high and extra-high voltage ranges. Helatape Tex fabric tapes are versatile and easy to write on.

Features and benefits

- Self-amalgamating insulation compound for sealing and padding cable jackets up to 1 kV
- Easily moulded by hand to conform to irregular shapes even during low temperatures
- Permanently elastic and resistant to ageing
- Perfect adhesion to metal and all types of cable insulations and jackets
- Provides excellent moisture sealing
- Resistant to salt water, ozone, oil and corrosive chemicals
- Excellent for repairing e.g. damaged cable sheaths against moisture ingress, where finishing with some layers of Helatape Flex will do the mechanical protection



Helatape Power self-amalgamating mastic is highly flexible.

MATERIAL	Isobutene-Isoprene-Rubber (butyl rubber) (IIR)
Operating Temperature	-10 °C to +105 °C
Intermittent Operating Temperature	+130 °C
Water Absorption	0.1 %
Volume Resistance	10 ¹⁵ Ω cm
Dielectric Strength	19.7 kV/mm



TYPE	Thickness (T)	Width (W)	Length (L)	Colour	Article-No.
HTAPE-POWER650	3.20	38.0	1.5 m	Black (BK)	711-10300

All dimensions in mm. Subject to technical changes. Minimum Order Quantity (MOQ) may differ from package content.



Self-amalgamating Tapes – Rubber Mastic Tape

HelaTape Power 660 RM

HellermannTyton offers a wide range of products for bundling, insulating, sealing and labeling cables and wires. PVC insulation tapes for low-voltage applications are available in various colors and dimensions. Self-welding, rubber-based tapes are ideal for insulating and sealing cables and connections from low to high and extra-high voltage ranges. HelaTape Tex fabric tapes are versatile and easy to write on.

Features and benefits

- Self-amalgamating rubber mastic tape
- EPR backing coated with a tacky, temperature-stable mastic adhesive
- Designed for electrical insulating and moisture sealing applications
- Can be used as cable jacket replacement
- Perfect adhesion and sealing for copper and aluminium wires
- Easily suitable to irregular shapes and surfaces
- Compatible with all extruded cable insulations
- UV, moisture, corrosion and chemical resistant
- Primary electrical insulation for bus bar connections rated up to 35 kV
- Excellent for repairing e.g. damaged cable sheaths against moisture ingress, where finishing with some layers of Helatape Flex will do the mechanical protection



HelaTape Power 660 is a very flexible rubber mastic sealing and padding tape.

MATERIAL	Ethylene Propylene Rubber (EPR), Isobutene-Isoprene-Rubber (butyl rubber) (IIR)
Operating Temperature	-30 °C to +90 °C
Intermittent Operating Temperature	+130 °C
Water Absorption	0.1 %
Tensile Strength	1.5 N/mm ²
Dielectric Strength	19.7 kV/mm



TYPE	Thickness (T)	Width (W)	Length (L)	Colour	Article-No.
HTAPE-POWER 660-RM	1.65	50.8	3.0 m	Black (BK)	711-00307

All dimensions in mm. Subject to technical changes. Minimum Order Quantity (MOQ) may differ from package content.



Self-amalgamating Tapes – Vinyl Mastic Tape

HelaTape Power 670 VM

HellermannTyton offers a wide range of products for bundling, insulating, sealing and labeling cables and wires. PVC insulation tapes for low-voltage applications are available in various colors and dimensions. Self-welding, rubber-based tapes are ideal for insulating and sealing cables and connections from low to high and extra-high voltage ranges. HelaTape Tex fabric tapes are versatile and easy to write on.

Features and benefits

- Easy to apply vinyl mastic tape
- Self-adhesive application - without stretching
- Mastic layer is very sticky and provides excellent moisture sealing
- Vinyl top layer provides additional protection
- Performs continuously. Even at low temperatures
- Primary insulation up to 1 kV
- Applicable to all extruded cable insulations
- UV and weather resistant



HelaTape Power 670 provides additional vinyl film protection to the mastic compound.

MATERIAL	Polyvinylchloride (PVC), Isobutene-Isoprene-Rubber (butyl rubber) (IIR)
Operating Temperature	-30 °C to +80 °C
Intermittent Operating Temperature	+95 °C
Water Absorption	0.9 %
Tensile Strength	16 N/mm ²
Elongation at break (min.)	200 %
Volume Resistance	10 ¹² Ω cm
Dielectric Strength	19.7 kV/mm



TYPE	Thickness (T)	Width (W)	Length (L)	Colour	Article-No.
HTAPE-POWER 670-VM	1.20	100.0	3.0 m	Black (BK)	711-00304

All dimensions in mm. Subject to technical changes. Minimum Order Quantity (MOQ) may differ from package content.



Self-amalgamating Tapes – Silicone Rubber Tape

HelaTape Power 800

HelaTape Power 800 is made from a special silicone and is Self-amalgamating Tapes. It is very suitable for sealing (waterproof and airtight), insulating and repairing. HelaTape Power 800 is not a conventional adhesive tape. It does not stick to other surfaces, but welds itself by wrapping it multiple times in an overlapping manner.

Features and benefits

- Self-amalgamating and self-cleaning, chemically cross-linked silicone rubber tape
- Triangular cross-section with centre line for precise half-overlapping
- Resistant to creepage and surface erosion
- Fuses into solid mass after application
- Weather, UV and oil resistant
- Recommended use for high temperature silicone insulated cables and outdoor machinery and transformers



HelaTape Power 800 is a silicone rubber tape with triangular cross-section.

MATERIAL	Silicone (SI)
Operating Temperature	-54 °C to +180 °C
Intermittent Operating Temperature	+260 °C
Tensile Strength	7.0 N/mm ²
Elongation at break (min.)	400 %
Volume Resistance	10 ¹⁴ Ω cm
Dielectric Strength	23.5 kV/mm



TYPE	Thickness (T)	Width (W)	Length (L)	Colour	Article-No.
HTAPE-POWER800	0.51	25.0	9.1 m	Grey (GY)	711-10400

All dimensions in mm. Subject to technical changes. Minimum Order Quantity (MOQ) may differ from package content.



Self-amalgamating Tapes – High Voltage Rubber Tape

HelaTape Power 810

HellermannTyton offers a wide range of products for bundling, insulating, sealing and labeling cables and wires. PVC insulation tapes for low-voltage applications are available in various colors and dimensions. Self-welding, rubber-based tapes are ideal for insulating and sealing cables and connections from low to high and extra-high voltage ranges. HelaTape Tex fabric tapes are versatile and easy to write on.

Features and benefits

- Self-amalgamating tape for insulating and jacketing splices up to 69 kV
- Halogen-free with outstanding corona, ozone and UV-resistance
- Ideal for sealing of terminations, electrical connections and cable jacket repair
- Void-free, electrically stable layering
- Protects e.g. bus bars against corrosion and contact
- Excellent moisture, corrosion and chemical resistance
- Compatible with all extruded cable insulations



HelaTape Power 810 for primary insulation up to 69 kV.

MATERIAL	Ethylene Propylene Rubber (EPR)
Operating Temperature	+90 °C
Intermittent Operating Temperature	+130 °C
Water Absorption	0.06 %
Tensile Strength	2.4 N/mm ²
Elongation at break (min.)	750 %
Volume Resistance	10 ¹⁶ Ω cm
Dielectric Strength	30 kV/mm



TYPE	Thickness (T)	Width (W)	Length (L)	Colour	Article-No.
HTAPE-POWER810	0.76	19.0	9.1 m	Black (BK)	711-10401

All dimensions in mm. Subject to technical changes. Minimum Order Quantity (MOQ) may differ from package content.



Self-amalgamating Tapes – High Voltage Rubber Tape (Linerless)

HelaTape Power 820

HellermannTyton offers a wide range of products for bundling, insulating, sealing and labeling cables and wires. PVC insulation tapes for low-voltage applications are available in various colors and dimensions. Self-welding, rubber-based tapes are ideal for insulating and sealing cables and connections from low to high and extra-high voltage ranges. HelaTape Tex fabric tapes are versatile and easy to write on.

Features and benefits

- Self-amalgamating, linerless tape for insulating and jacketing splices up to 69 kV
- Excellent electrical, chemical and physical properties
- Building stress cones and jacketing of terminations, bus bars and joints
- Quicker application due to linerless design
- The lack of liner causes less waste
- Uniform and void-free layering
- Very flexible to conform to the most complex shapes
- Compatible with all extruded cable insulations



The high-voltage tape HelaTape Power 820 yields a uniform and void-free build-up.

MATERIAL	Ethylene Propylene Rubber (EPR)
Operating Temperature	-30 °C to +90 °C
Intermittent Operating Temperature	+130 °C
Water Absorption	0.06 %
Tensile Strength	2.8 N/mm ²
Elongation at break (min.)	750 %
Volume Resistance	10 ¹⁶ Ω cm
Dielectric Strength	31.5 kV/mm

RoHS

TYPE	Thickness (T)	Width (W)	Length (L)	Colour	Article-No.
HTAPE-POWER820	0.76	19.0	9.1 m	Black (BK)	711-10402

All dimensions in mm. Subject to technical changes. Minimum Order Quantity (MOQ) may differ from package content.



Technical Tapes – Vinyl Bundling Tape

HelaTape Allround 1500

Allround 1500 – Electricians Duct Tape is designed for bundling, holding, fixing and maintenance applications. It can be also used as temporary surface protection of steel and aluminium parts.

Features and benefits

- Vinyl film coated with high quality rubber adhesive
- Excellent performance and durability
- Easy to tear
- No cloth – does not absorb water
- Used for bundling, holding, fixing and maintenance
- This product has no electrical insulating properties

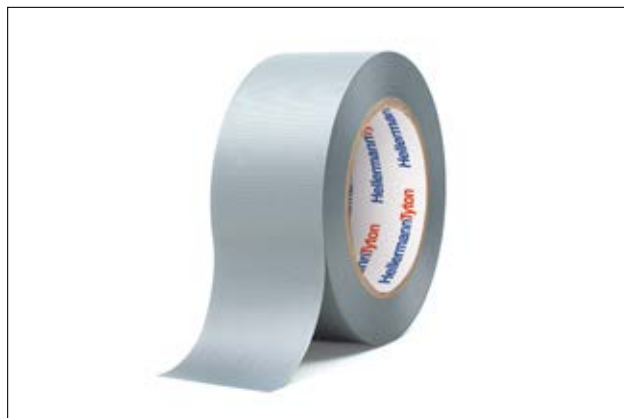

HelaTape Allround 1500 – universal and very strong vinyl bundling tape.

MATERIAL	Polyvinylchloride (PVC)
Adhesion to Steel	1.5 N/10 mm
Adhesion to Backing	1.5 N/10 mm
Elongation at break (min.)	150 %
Operating Temperature	-10 °C to +90 °C



TYPE	Thickness (T)	Width (W)	Length (L)	Colour	Article-No.
HTAPE-ALLROUND1500	0.15	51.0	46.0 m	Grey (GY)	710-01000

All dimensions in mm. Subject to technical changes. Minimum Order Quantity (MOQ) may differ from package content.



Please note: Some or all of the products listed here have these approvals, or have one or more sustainable attributes. Please see our website for the latest details.



Technical Tapes - Cloth Tape

HelaTape Tex

HellermannTyton offers a wide range of products for bundling, insulating, sealing and labeling cables and wires. PVC insulation tapes for low-voltage applications are available in various colors and dimensions. Self-welding, rubber-based tapes are ideal for insulating and sealing cables and connections from low to high and extra-high voltage ranges. HelaTape Tex fabric tapes are versatile and easy to write on.

Features and benefits

- High quality PE-coated cloth tape with good weather resistance
- Total thickness of 0.31 mm for high tensile strength
- Highly tear-resistant in longitudinal direction
- Easy to tear-off by hand in transverse direction
- Matt surface finish for use in stage constructions and for exhibitions to avoid light reflections
- Useful for various applications like bundling, fixing, identification, marking and protection
- HelaTape Tex can be removed without residues due to high quality rubber based adhesive



HelaTape Tex is available in various colours and sizes.

MATERIAL	Cotton (CO)
Operating Temperature	-30 °C to +80 °C
Adhesion to Backing	3.0 N/10 mm
Elongation at break (min.)	10 %
Breaking Strength	64 N/10 mm



TYPE	Thickness (T)	Width (W)	Length (L)	Colour	Article-No.
HTAPE-TEX-19x10	0.31	19.0	10.0 m	Black (BK)	712-00204
	0.31	19.0	10.0 m	Blue (BU)	712-00200
	0.31	19.0	10.0 m	Green (GN)	712-00203
	0.31	19.0	10.0 m	Grey (GY)	712-00206
	0.31	19.0	10.0 m	Red (RD)	712-00201
	0.31	19.0	10.0 m	White (WH)	712-00205
	0.31	19.0	10.0 m	Yellow (YE)	712-00202
HTAPE-TEX-19x50	0.31	19.0	50.0 m	Black (BK)	712-00504
	0.31	19.0	50.0 m	Blue (BU)	712-00500
	0.31	19.0	50.0 m	Green (GN)	712-00503
	0.31	19.0	50.0 m	Grey (GY)	712-00506
	0.31	19.0	50.0 m	Red (RD)	712-00501
	0.31	19.0	50.0 m	White (WH)	712-00505
	0.31	19.0	50.0 m	Yellow (YE)	712-00502
HTAPE-TEX-50x50	0.31	50.0	50.0 m	Black (BK)	712-00904
	0.31	50.0	50.0 m	Blue (BU)	712-00900
	0.31	50.0	50.0 m	Green (GN)	712-00903
	0.31	50.0	50.0 m	Grey (GY)	712-00906
	0.31	50.0	50.0 m	Red (RD)	712-00901
	0.31	50.0	50.0 m	White (WH)	712-00905
	0.31	50.0	50.0 m	Yellow (YE)	712-00902

All dimensions in mm. Subject to technical changes. Minimum Order Quantity (MOQ) may differ from package content.



Wire Harness Tape – Hand-tearable Cloth Tape

HelaTape Protect 180

HelaTape Protect tapes are preferably used for cable harnessing in different industries.

Features and benefits

- High quality polyester fabric harnessing tape
- Rubber-based adhesive offers very good heat and media resistance
- High temperature stability from -40 °C to +125 °C
- Temperature resistance tested according to LV312
- Very good resistance against abrasion
- Material is very flexible and tearable by hand
- Excellent ageing resistance, and resistant to rotting in wet or damp conditions such as e.g. white goods and automotive, etc.



HelaTape Protect 180 is very flexible and used for cable harnessing.

MATERIAL	Polyester (PET)
Operating Temperature	-40 °C to +125 °C
Adhesion to Steel	3.0 N/10 mm
Adhesion to Backing	3.0 N/10 mm
Elongation at break (min.)	15 %
Breaking Strength	65 N/10 mm



TYPE	Thickness (T)	Width (W)	Length (L)	Colour	Article-No.
HTAPE-PROTECT180	0.18	19.0	25.0 m	Black (BK)	712-10002

All dimensions in mm. Subject to technical changes. Minimum Order Quantity (MOQ) may differ from package content.



Wire Harness Tape – Strong, High Temperature Cloth Tape

HelaTape Protect 250

HelaTape Protect tapes are preferably used for cable harnessing in different industries.

Features and benefits

- High temperature polyester fabric harnessing tape
- Special acrylate-based adhesive offers very good heat and media resistance
- Very high temperature stability from -40 °C to +150 °C
- Temperature and humidity resistance tested according to LV312
- Very good resistance against abrasion
- Material is very flexible and easy to handle
- Provides long term reliability under varying and extreme environmental conditions
- Excellent ageing resistance, and resistant to rotting in wet or damp conditions such as e.g. white goods and automotive, etc.



HelaTape Protect 250 is designed for cable harnessing and offers a very high temperature resistance.

MATERIAL	Polyester (PET)
Operating Temperature	-40 °C to +150 °C
Adhesion to Steel	3.2 N/10 mm
Adhesion to Backing	3.2 N/10 mm
Elongation at break (min.)	20 %
Breaking Strength	180 N/10 mm



TYPE	Thickness (T)	Width (W)	Length (L)	Colour	Article-No.
HTAPE-PROTECT250	0.25	19.0	25.0 m	Black (BK)	712-10003

All dimensions in mm. Subject to technical changes. Minimum Order Quantity (MOQ) may differ from package content.



Wire Harness Tape – Soft and Flexible Fleece Tape

HelaTape Protect 300

HelaTape Protect tapes are preferably used for cable harnessing in different industries.

Features and benefits

- Soft polyester fleece harnessing tape
- High noise reduction and very high resistance against abrasion
- Synthetic rubber based adhesive offers good heat and media resistance
- High temperature stability from -40 °C to +105 °C
- Material is very flexible and tearable by hand
- Excellent ageing resistance, and resistant to rotting in wet or damp conditions such as e.g. white goods and automotive, etc.



HelaTape Protect 300 provides high noise reduction and media resistance.

MATERIAL	Polyester (PET)
Operating Temperature	-40 °C to +105 °C, (+105 °C for 500 h)
Adhesion to Steel	2.0 N/10 mm
Adhesion to Backing	2.0 N/10 mm
Elongation at break (min.)	10 %
Breaking Strength	30 N/10 mm



TYPE	Thickness (T)	Width (W)	Length (L)	Colour	Article-No.
HTAPE-PROTECT300	0.30	19.0	25.0 m	Black (BK)	712-10001

All dimensions in mm. Subject to technical changes. Minimum Order Quantity (MOQ) may differ from package content.

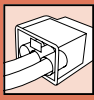

Connectors - For all Types of Wire

HelaCon Plus Releasable

The HelaCon Plus Releasable connectors are used for all types of wire to connect cable and conductors in the field of electrical installation. The connectors can be used in all kinds of junction boxes either on-wall or flush-mounted. HelaCon offers the best possible solution when convenient processing and maximum safety is required.

Features and benefits

- Universal push-in wire connector for solid, stranded and fine-stranded wires
- Compact size connector
- Wire clamping range: 0.2 - 4.0 mm²
- Separate voltage test entry on the top
- For proper fixing that can be visually checked through transparent housing
- Safe application, installation and maintenance



HelaCon Plus Releasable Box and Blister 2.

MATERIAL	Polycarbonate (PC)
Max Current	32 A
Max Voltage	450 V
Wire Range (VDE) in mm²	0.2 to 4.0 mm ² all types of wire
Stripping Length	10 mm
Flammability	UL 94 V0
Operating Temperature	-30 °C to +85 °C



TYPE	Drawing	Number of Conductors	Colour	Width (W)	Height (H)	Length (L)	Pack Cont.	Article-No.
HCRN-2-Blister		2	Transparent (CL)	20.5	14.0	12.0	10 pcs.	148-90062
HCRN-2		2	Transparent (CL)	20.5	14.0	12.0	80 pcs.	148-90059
HCRN-3-Blister		3	Transparent (CL)	20.5	14.0	17.0	8 pcs.	148-90063
HCRN-3		3	Transparent (CL)	20.5	14.0	17.0	50 pcs.	148-90060
HCRN-5-Blister		5	Transparent (CL)	20.5	14.0	26.0	5 pcs.	148-90064
HCRN-5		5	Transparent (CL)	20.5	14.0	26.0	30 pcs.	148-90061

All dimensions in mm. Subject to technical changes. Minimum Order Quantity (MOQ) may differ from package content.



Please note: Some or all of the products listed here have these approvals, or have one or more sustainable attributes. Please see our website for the latest details.



Connectors - For Solid and Stranded Wires

HelaCon Plus Mini

HelaCon connectors are used for fast, easy and reliable connection and distribution of cable and conductors in electrical installation applications. The new generation of HelaCon Plus Mini wire connectors can be applied tool-free using the push-in technology. HelaCon Plus Mini uses a double spring which is approved for solid and stranded wires.

Features and benefits

- 40 % smaller – Space saving design
- Low insertion force – Easy to use, saves time on installation
- Easy access to voltage test entry and innovative port shape design
- Correct installation can be visually checked through transparent housing
- Different colour codes for easy identification of size
- Allows different conductor diameters in each entry
- Safe application, installation and maintenance
- Practical Variobox with 350 pcs. of selected HCPM wire connectors available (148-90046)

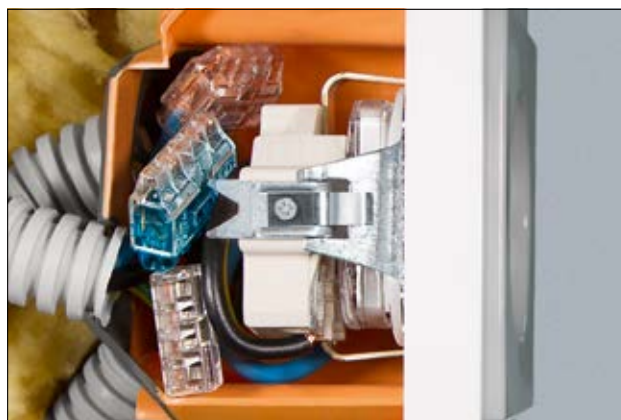

HelaCon Plus Mini fits perfect in every space limited situation.

MATERIAL	Polycarbonate (PC)	
Max Current	24 A	
Max Voltage	450 V	600 V
Wire Range (VDE) in mm²	0.5 to 2.5 mm ² solid wires / 1.0 to 2.5 mm ² stranded wires	
Stripping Length	11 mm	
Flammability	UL 94 V0	
Operating Temperature	-30 °C to +85 °C	

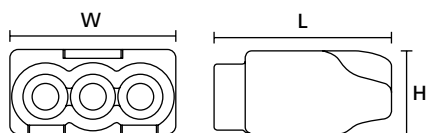

HelaCon Plus Mini front view

HelaCon Plus Mini side view

TYPE	Drawing	Number of Conductors	Colour	Width (W)	Height (H)	Length (L)	Pack Cont.	Article-No.
HCPM-2-Blister		2	Transparent (CL), Yellow (YE)	10.8	7.7	16.5	20 pcs.	148-90054
HCPM-2		2	Transparent (CL), Yellow (YE)	10.8	7.7	16.5	150 pcs.	148-90036
HCPM-3		3	Orange (OG), Transparent (CL)	15.1	7.7	16.5	100 pcs.	148-90037
HCPM-3-Blister		3	Transparent (CL), Orange (OG)	15.1	7.7	16.5	18 pcs.	148-90055
HCPM-4-Blister		4	Transparent (CL)	19.4	7.7	16.5	10 pcs.	148-90056
HCPM-4		4	Transparent (CL)	19.4	7.7	16.5	100 pcs.	148-90038

All dimensions in mm. Subject to technical changes. Minimum Order Quantity (MOQ) may differ from package content.



Please note: Some or all of the products listed here have these approvals, or have one or more sustainable attributes. Please see our website for the latest details.

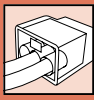

Connectors - For Solid and Stranded Wires

HelaCon Plus Mini

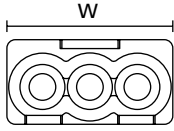
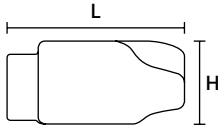
HelaCon Plus Mini
front view

HelaCon Plus Mini side view

TYPE	Drawing	Number of Conductors	Colour	Width (W)	Height (H)	Length (L)	Pack Cont.	Article-No.
HCPM-5-Blister		5	Transparent (CL), Blue (BU)	23.7	7.7	16.5	10 pcs.	148-90057
HCPM-5		5	Transparent (CL), Blue (BU)	23.7	7.7	16.5	75 pcs.	148-90039
HCPM-6		6	Transparent (CL), Violet (VT)	28.0	7.7	16.5	50 pcs.	148-90040
HCPM-8		8	Transparent (CL), Black (BK)	36.6	7.7	16.5	50 pcs.	148-90041
HCPM Variobox 350		-	Transparent (CL)	120.0	7.7	16.5	350 pcs.	148-90046

All dimensions in mm. Subject to technical changes. Minimum Order Quantity (MOQ) may differ from package content.



Please note: Some or all of the products listed here have these approvals, or have one or more sustainable attributes. Please see our website for the latest details.



Connectors - For Lighting Installation

HelaCon Lux

A typical application is lighting installation, where the solid conductor from concealed cabling has to be connected to a flexible conductor for lighting. The 2/1 variant allows the looping through of the supply lines for additional devices.

The conductor on the output/lighting side can easily be inserted by pressing the locking mechanism and can be released in the same way at any time. The lighting side can carry any kind of conductor and makes HelaCon Lux connectors also useful to connect devices that carry flexible connecting cables like control devices e.g. for blinds, fans and other drives.

Features and benefits

- Best suitable to connect solid with flexible wire
- Combines push-in connector with lock/unlock spring mechanism
- For fine-stranded conductors at lighting input
- Use with typical voltage current of 450 V / 24 A
- Either one or two inputs for solid conductor on installation side
- Very flexible application
- Tool-free application for easy, time-saving, safe connection
- Especially for overhead work and when wires are difficult to access



Quick installation and release of lighting devices with HelaCon Lux.

MATERIAL	Polyamide 6.6 (PA66)
Max Current	24 A
Max Voltage	450 V
Wire Range (VDE) in mm²	0.5 mm ² - 2.5 mm ²
Stripping Length	11 mm
Flammability	UL 94 V2
Operating Temperature	-5 °C to +100 °C

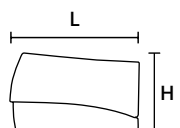

HelaCon Lux side view



HelaCon Lux front view

TYPE	Drawing	Number of Conductors	Colour	Width (W)	Height (H)	Length (L)	Pack Cont.	Article-No.
HECL-1/1		2	Grey (GY)	8.1	15.8	20.8	100 pcs.	148-90022
HECL-2/1-Blister		3	White (WH)	9.5	15.8	20.8	10 pcs.	148-90058
HECL-2/1		3	White (WH)	9.5	15.8	20.8	100 pcs.	148-90023

All dimensions in mm. Subject to technical changes. Minimum Order Quantity (MOQ) may differ from package content.



Please note: Some or all of the products listed here have these approvals, or have one or more sustainable attributes. Please see our website for the latest details.



Cable Installation System - Cable Scout+

Cable Scout+ Rod Sets

Cable Scout+ is a professional cable routing tool which enables installers to easily route cables, saving time, even with the most challenging installations. The rods are manufactured from high quality Glass Reinforced Plastic (GRP), which enables a load carrying capacity of up to 200 kg. Cable Scout+ offers a range of features which allows the installer to illuminate, grip, inspect and retrieve by using the range of accessories. Cable Scout+ is supplied in a useful durable bag which contains the rods and accessories all in one place.

Features and benefits

- Professional cable installation tool
- Enables time savings to be achieved even with challenging installations
- Rods manufactured from high quality Glass Reinforced Plastic (GRP)
- Load carrying capacity of 200 kg
- Range of accessories enabling the installer to illuminate, grip inspect and retrieve.
- Rods & accessories contained in a useful durable storage bag



All components stored neat and tidy with the Cable Scout+ Deluxe set.



Basic Set.



Handy Set.

TYPE	Description	Content Rods	Rod Capacity (m)	Content Accessories	Article-No.
CS-SB	Basic Set: designed to perform basic cable installation	10 rods x 1 m (white)	10.0 m	15 cm white flexi lead, gender changer, tuff hook, mini eye	897-90000
CS-SD	Deluxe Set: the most comprehensive set aimed for carrying out larger installations	2 rods x 1 m (white) 6 rods x 1 m (red) 2 rods x 1 m (blue)	10.0 m	15 cm white flexi lead, split ring, gender changer, tuff hook, mini eye, domed bullet, flat bullet, beam, single magnet	897-90001
CS-SH	Handy Set: made up for fitting in a tool box	1 rod x 40 cm (white) 2 rods x 40 cm (red) 1 rod x 40 cm (blue)	1.6 m	40 cm white flexi lead, domed bullet, mini hook, mini eye	897-90003

Subject to technical changes.



Cable Installation System - Cable Scout+

Cable Scout+ Rod Pairs

Additionally available pairs of rods.

Features and benefits

- Professional cable installation tool
- Enables time savings to be achieved even with challenging installations
- Rods manufactured from high quality Glass Reinforced Plastic (GRP)
- Load carrying capacity of 200 kg
- Range of accessories enabling the installer to illuminate, grip inspect and retrieve.
- Rods & accessories contained in a useful durable storage bag

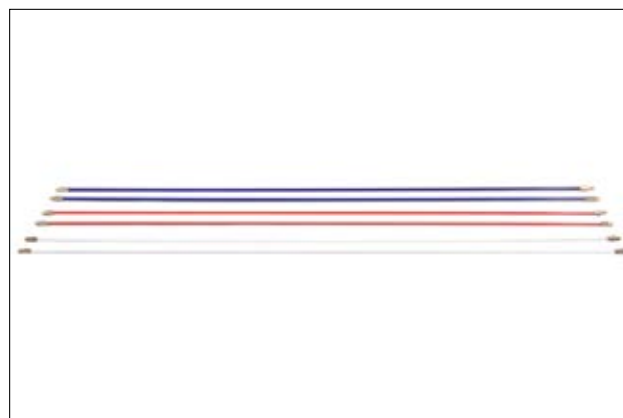

Overview of the rods selection.

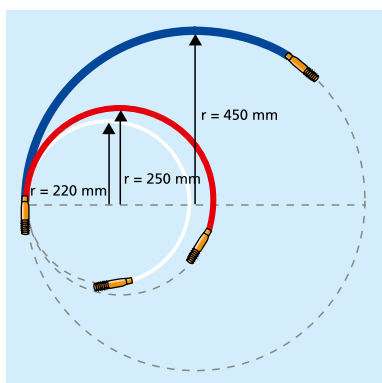

Overview on Cable Scout+ marginal bending radii.

TYPE	Content Rods	Flexibility	Ø (D)	Article-No.
CS-P6	One pair of 1 m blue rods	strong	6.0	897-90007
CS-PN	One pair of 1 m nylon rods	fully flexible	5.0	897-90008
CS-P5	One pair of 1 m red rods	medium	5.0	897-90006
CS-P4	One pair of 1 m white rods	flexible	4.0	897-90005

All dimensions in mm. Subject to technical changes.



Cable Installation System - Cable Scout+

Cable Scout+ Accessories

Cable Scout+ is supplied with a range of useful standard accessories. Additional accessories can be purchased separately. Cable Grips are designed to grip objects and provide a reliable and time saving method of securing cables & pipes to the rods. Just open the grip by compressing the braid, push the grip over the cable or pipe and release the grip, which will contract and establish a tight grip on the cable or pipe to the rod set.

Features and benefits

- Accessory kit includes a lot of useful tools
- User can inspect and retrieve
- Cable grips allow a very fast way to pull cables
- Whisk glides smoothly over obstacles
- Strong magnet lifts metallic tools up to 2.5 kg weight



Cable Grips are available in five different sizes to attach a wide range of cable diameters.



Cable Scout+ and Grip.



The whisk allows the rod to glide over obstructions easily.



Cable Pulling Lubricant reduces friction during the installation of cables.

TYPE	Drawing	Description	Article-No.
CS-SA		Accessory Kit: Includes a 15 cm long flexi lead, gender changer, mini hook, tuff hook, mini eye, split ring, round bullet, flat bullet, single magnet, chain	897-90004
CS-ACG1630		Cable Grip: Suitable for diameter 1.6 - 3.0 cm	897-90027
CS-ACG0415		Cable Grip: Suitable for diameters 0.4 - 1.5 cm	897-90026
CS-AWL		Large whisk: designed to glide over more uneven surfaces such as roof tiles.	897-90019
CS-AW		Whisk: Enables cables to glide over rough and uneven surfaces.	897-90018
CABLESCOUT-GEL		Cable pulling lubricant: provides reliable protection against cable jacket damage by reducing the frictional resistance up to 80 %.	897-90031

Subject to technical changes.



Downlight Covers - For Residential Buildings

SpotClip-I

SpotClip-I is a unique product that has been developed for mounting down lights in dry mortarless construction and acoustic construction applications.

The innovative, 4-leg ceiling brace has a number of outstanding features and is suitable for use in both panelling and plasterboard.

SpotClip-I consists of non-flammable, fibreglass reinforced polyamide and offers a number of thermal and mechanical benefits and can even be installed retrospectively.

As a result, it opens up a variety of possibilities for applications in both old and new buildings.

SpotClip-I can be used in ceiling cavities with diameters of 62 to 90 mm. SpotClip-I ensures that a safe distance is kept between the down light, insulation foil and roof insulation.

It reduces the risk of damage being caused to any insulation material as a result of overheating and heat accumulation and may also have a positive effect on the life time of the lamp.

Features and benefits

- Mount down lights in dry, mortarless construction and acoustic construction
- Innovative, 4-leg ceiling spacer
- Suitable for both panelling and plasterboard
- Non-flammable, fibreglass reinforced polyamide
- Thermal and mechanical benefits
- Can be installed after construction, useful for both old and new buildings
- Use in ceiling cavities 62-90 mm in diameter
- Keeps safe distance between down light, insulation foil and roof insulation
- Reduces risk of damage to insulation from overheating, heat accumulation
- Improves life span and reliability of lamps
- Tested according to EN 60598-1, EN 60598-2-2, and NF C 15100



SpotClip-II ensures reliability and safety of lighting installations.



Cable retainers on the heat protection tool hold the supply cable in place.



1. Use the delivered tool to install SpotClip in the fixing hole as easy as possible.



2. Push the spikes into the plasterboard to prevent shifting and disconnect the tool.



3. Start the installation of the downlight in a safe way.

MATERIAL	Polyamide 6.6, glass-fibre reinforced (PA66GF15)
Operating Temperature	-20 °C to +120 °C
Flammability	Glow Wire Test (960 °C), UL 94 V0

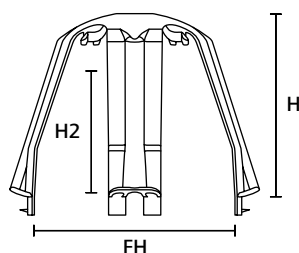

SpotClip-I

TYPE	Hole Ø (FH) min.	Hole Ø (FH) max.	Height (H)	Height (H2)	Colour	Pack Cont.	Article-No.
SpotClip-I	62.0	90.0	82.0	70.0	Black (BK)	10 pcs.	148-00076

All dimensions in mm. Subject to technical changes. Minimum Order Quantity (MOQ) may differ from package content.



Downlight Covers - For Residential Buildings

SpotClip-II

SpotClip-II has been developed for use with large LED spotlights. Additional, flexible legs allow use with blown-in insulation material. The legs can be easily removed to facilitate cable installation. The downlight cover can be inserted easily into the ceiling cavity and offers valuable savings on installation time. SpotClip creates a reliable gap between the light bulb and the insulation material, reducing the risk of overheating and heat accumulation.

Features and benefits

- SpotClip-II has been developed for bulbs up to 95 mm height
- Ensures safety distance between downlight, damp-proof foil and insulation material
- Flexible installation during or after construction
- Additional spikes at the end of the legs prevent SpotClip shifting
- Suitable for fixing into holes from 62 - 90 mm diameter
- Remains rigid even at higher temperatures
- Flame retardant material according to UL94-V0
- Improves life span and reliability of lamps
- Tested according to EN 60598-1, EN 60598-2-2, and NF C 15100

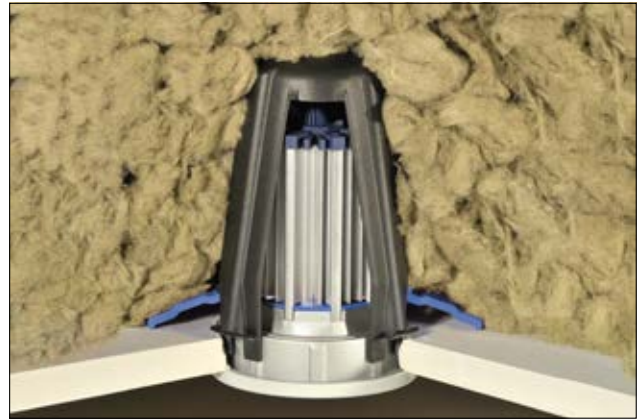

The additional 4 legs on SpotClip-II allow use with blown-in cavity insulation.



SpotClip-II downlight cover with 4 additional flexible legs.



SpotClip-II shown using standard insulation wool.



SpotClip-I and SpotClip-II for maximum downlight heights of 70 mm and 95 mm respectively.



Retaining spikes and support wings hold SpotClip-II in the required position.



1. Use the delivered tool to install SpotClip-II in the fixing hole as easy as possible.



2. Push the spikes into the plasterboard to prevent shifting and disconnect the tool.



3. Start the installation of the downlight in a safe way.



Downlight Covers - For Residential Buildings

SpotClip-II

MATERIAL	Polyamide 6.6, glass-fibre reinforced (PA66GF15)
Operating Temperature	-20 °C to +120 °C
Flammability	Glow Wire Test (960 °C), UL 94 V0

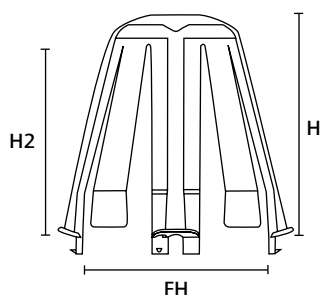

SpotClip-II

TYPE	Hole Ø (FH) min.	Hole Ø (FH) max.	Height (H)	Height (H2)	Colour	Pack Cont.	Article-No.
SpotClip-II	62.0	90.0	107.0	95.0	Black (BK)	10 pcs.	148-00098

All dimensions in mm. Subject to technical changes. Minimum Order Quantity (MOQ) may differ from package content.



Downlight Covers - For Residential Buildings

SpotClip-III

This further development of SpotClip-II allows the use of an existing power supply. In the case of a spot without power supply, this added straight leg can be cut easily and removed manually. It helps to avoid contact between the insulation and the external power supply of the spot. SpotClip-III will fit to all standard applications with solid insulation material. It is delivered flat with flexible legs. They can be locked within seconds. The height of the this mounting device is depending on the fixing hole diameter. SpotClip-III is suitable for LED and Halogen downlights with a fixing hole diameter from 62 mm to 120 mm. The maximum product height is 130 mm depending on the fixing hole diameter.

Features and benefits

- A mounting support for the external power supply unit provides more space for the downlight installation
- Ensures safety distance between the downlight, damp-proof foil and insulation material
- Flexible installation during or after construction
- Additional spikes at the end of the legs prevent SpotClip shifting
- Prevents damage to insulation material caused by overheating
- Flame retardant material according to UL94-V2
- Improves life span and reliability of lamps
- Faster and easier installation and replacement of lamps
- Tested according to EN 60598-1, EN 60598-2-2, and NF C 15100



SpotClip-III downlight cover.



SpotClip-III downlight cover- Easy-to-mount legs with one click folding function.



SpotClip-III for downlight application with external power supply.



One cable retainer to fix the power supply cable at the top.



Click and fix mounting mechanism for the 3 flexible legs.



New leg design combined with retaining spikes for high stability throughout installation.



1. Insert the mounting support through the fixing hole.



2. Press the spikes into the plasterboard to ensure stability of SpotClip-III.



3. Install the downlight.



Downlight Covers - For Residential Buildings

SpotClip-III



4. Connect the power supply unit and fix the cable in the cable retainer.

MATERIAL	Polyamide 6.6, heat stabilised (PA66HS)
Operating Temperature	-40 °C to +105 °C, (+105 °C for 500 h)
Flammability	UL 94 V2, Glow Wire Test (960 °C)

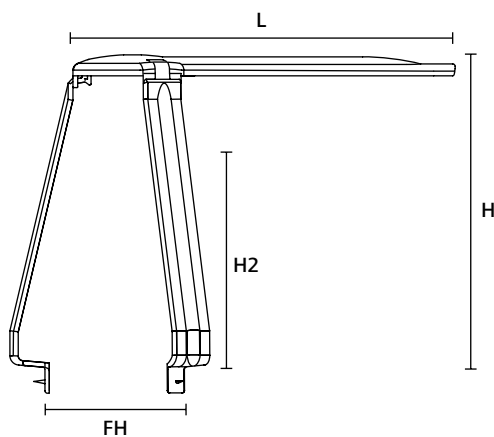

SpotClip-III

TYPE	Hole Ø (FH) min.	Hole Ø (FH) max.	Height (H)*	Height (H2)*	Length (L)	Colour	Pack Cont.	Article-No.
SpotClip-III	62.0	120.0	130.0	115.0	160.0	Black (BK)	5 pcs.	148-00121

All dimensions in mm. Subject to technical changes. Minimum Order Quantity (MOQ) may differ from package content. * For fixing hole diameter 65 mm.



Downlight covers - For residential buildings

SpotClip-IV-Slim

The SpotClip-IV-Slim ensures a safety distance between downlight, damp-proof foil and insulation material and can thereby prevent the risk of overheating and premature deterioration of the lighting. It is developed for safe use and installation of ultra-flat LED lights and suitable for ceiling cut-outs with a recessed diameter of 73 to 83 mm. Four additional and flexible tabs prevent contact between loose insulation material and the luminaire, making it ideal for use with bulk and blown insulation materials. Removable tabs allow to accommodate a transformer or to facilitate cable installation. The SpotClip-IV-Slim can be installed during or after construction. It is tested according to EN 60598-1, EN 60598-2-2, and NF C 15100.

Features and benefits

- Adaptation and dimensioning to the booming LED lighting market
- Reduction of size of more than 50%
- Simplify installation in tight spaces
- Suitable only for extra flat LED recessed luminaires



SpotClip-IV-Slim - Application with injected wool.



SpotClip-IV-Slim shown using standard insulation wool/ glass wool.



Application on the ceiling.

MATERIAL	Polyamide 6.6, glass-fibre reinforced (PA66GF15)
Operating Temperature	-20 °C to +120 °C
Flammability	Glow Wire Test (960 °C), UL 94 V0

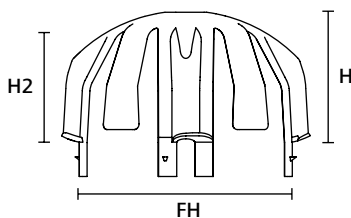

SpotClip-IV-Slim

TYPE	Hole Ø (FH) min.	Hole Ø (FH) max.	Height (H)	Height (H2)	Colour	Pack Cont.	Article-No.
SpotClip-IV-Slim	73.0	83.0	50.0	43.0	Black (BK)	10 pcs.	148-00146

All dimensions in mm. Subject to technical changes. Minimum Order Quantity (MOQ) may differ from package content.

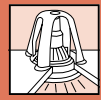

Downlight Covers - For Residential Buildings

SpotClip-Box

SpotClip-Box has been designed especially for passive houses. This innovative downlight cover prevents contact between insulation material and the bulb. The insulation remains continuous, thus avoiding any breach in the integrity of insulation in the passive house. SpotClip-Box is suitable for LED and compact fluorescent-lamp downlights with a diameter of up to 75 mm and a maximum height of 130 mm. It is available as a complete kit, including HelaCon Lux wire connectors and all necessary mounting components.

Features and benefits

- Suitable for all types of suspended ceilings and a variety of insulation materials
- Ensures safety distance between the downlight, damp-proof foil and insulation material
- Additional spikes at the bottom of the product prevent shifting during installation
- Connection without the need for screws, with HelaCon Lux connectors included
- Prevents damage to insulation material caused by overheating
- Improves life span and reliability of lamps
- Quick and easy one-click installation with bayonet mechanism
- Can also be used to install downlights and speakers in concrete ceilings constructed on-site
- Tested according to EN 60598-1, EN 60598-2-2, and NF C 15100



SpotClip-Box is a downlight cover supplied as a complete kit.



SpotClip-Box - Especially designed for passive house applications.



View inside the SpotClip-Box.



HelaCon Lux connected to the power supply.



Seal the complete SpotClip-box using the end cap and grommet.



1. Mount the bottom plate over the drilled fixing hole and install the downlight housing.



2. Connect the power supply to the lamp socket with the HelaCon Lux wire connectors included and lock it with the bayonet coupling.



3. Connect the bulb to the socket and lock into the correct position.



4. Insulation material can now be applied.

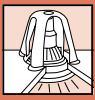

Downlight Covers - For Residential Buildings

SpotClip-Box

MATERIAL	Polyamide 6.6, heat stabilised (PA66HS)
Operating Temperature	-40 °C to +105 °C, (+105 °C for 500 h)
Flammability	UL 94 V2, Glow Wire Test (960 °C)

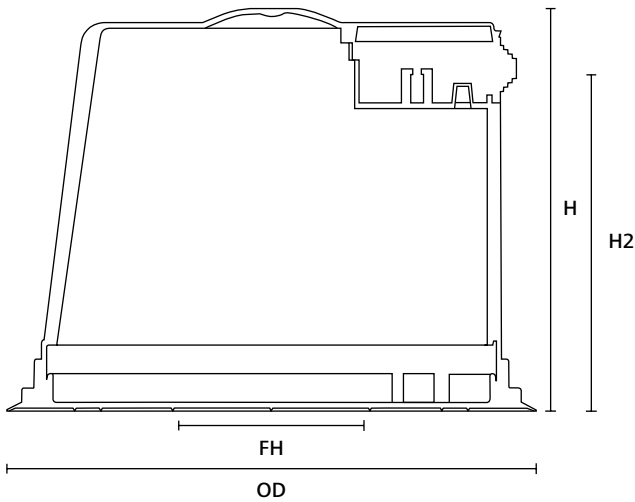

SpotClip-Box

TYPE	Hole Ø (FH) min.	Hole Ø (FH) max.	Height (H)	Height (H2)	Outside Ø (OD)	Colour	Pack Cont.	Article-No.
SpotClip-Box FR	75.0	75.0	140.0	130.0	184	Black (BK)	1 pc.	148-00123

All dimensions in mm. Subject to technical changes. Minimum Order Quantity (MOQ) may differ from package content.



Downlight Covers - For Industrial Buildings

SpotClip-Kit

SpotClip-Kit has been designed for use primarily in industrial and office buildings for downlights with larger dimensions. The packaging kit consists of three legs and a mounting plate. The legs are available in two different lengths (150 mm and 240 mm). SpotClip-Kit has six selectable fixing positions in the mounting plate, making it suitable for downlights of differing dimensions. SpotClip-Kit 150 is suitable for downlights with a diameter from 100 mm up to 270 mm and with a maximum height of 140 mm. SpotClip-Kit 240 is suitable for downlights with a diameter from 170 mm up to 310 mm and with a maximum height of 230 mm. SpotClip-Kit can be combined with SpotClip-Plate.

Features and benefits

- Installation from the top or bottom in all types of suspended ceilings
- Ensures safety distance between downlight, damp-proof foil and insulation material
- Flexible installation during or after construction, suitable for use in existing and new buildings
- Additional spikes at the end of the legs prevents shifting during installation
- Intelligent cable routing with eyelet at the top
- Prevents damage to insulation material caused by overheating
- Heavy-duty leg design prevents long-term deformation
- Improves life span and reliability of the lamp
- Tested according to EN 60598-1, EN 60598-2-2, and NF C 15100



SpotClip-Kit downlight cover is available in two sizes.



SpotClip-Kit 150 used in a suspended ceiling.



SpotClip-Kit 240 applied with a fixed sheet of insulating material.



SpotClip-Kit 150 is used for fixing hole diameters from 100 mm to 270 mm.



SpotClip-Kit 240 is used for fixing hole diameters from 170 mm to 310 mm.



The feet position can be very easily adjusted using the click and release system.



A robust design combined with retaining spikes ensures high stability.



SpotClip-Kit 150 is delivered as a self-assembly set.



SpotClip-Kit 240 is delivered as a self-assembly set.

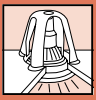

Downlight Covers - For Industrial Buildings

SpotClip-Kit

MATERIAL	Polyamide 6.6, heat stabilised (PA66HS)
Operating Temperature	-40 °C to +105 °C, (+105 °C for 500 h)
Flammability	UL 94 V2, Glow Wire Test (960 °C)

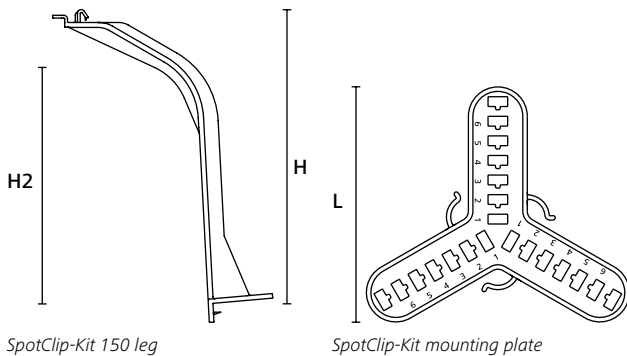

SpotClip-Kit 150 leg

SpotClip-Kit mounting plate

TYPE	Hole Ø (FH) min.	Hole Ø (FH) max.	Height (H)	Height (H2)	Length (L)	Colour	Pack Cont.	Article-No.
SpotClip-Kit 150	100.0	270.0	157.0	140.0	120.0	Black (BK)	1 pc.	148-00119
SpotClip-Kit 240	170.0	310.0	247.0	230.0	120.0	Black (BK)	1 pc.	148-00120

All dimensions in mm. Subject to technical changes. Minimum Order Quantity (MOQ) may differ from package content.



Downlight Covers - For Industrial Buildings

SpotClip-Plate

SpotClip-Plate has been developed especially for installation in suspended grid ceilings in order to avoid damage and cracks in the ceiling plates caused by the weight of heavy downlights. The product dimensions of 592 mm x 592 mm mean that it fits perfectly into standard grid ceilings with a width of 600 mm. The pre-cut design makes it suitable for installation of the most commonly used downlights with a diameter from 75 mm to 314 mm.

Please check if your grid ceiling size corresponds to the side length of 600 mm. Depending on the manufacturer and country this can vary between 600 mm and 625 mm.

Features and benefits

- SpotClip-Plate distributes the load of the downlight equally across the suspended ceiling construction
- Flexible installation during or after construction, useful for both existing and new buildings
- Remains rigid even at higher temperature
- Flame retardant material according to UL94-V2
- Improves life span and reliability of lamps
- Faster and easier installation and replacement of the lamp
- Tested according to EN 60598-1, EN 60598-2-2, and NF C 15100



SpotClip-Plate fits perfect into standard grid ceilings with a width of 600 mm.



SpotClip-Plate has been developed for applications with heavy downlights in suspended grid ceilings.



SpotClip-Plate comes in 16 pre-cut fixing hole diameter sizes.



Choose the required diameter and cut with a handsaw.



Use the SpotClip-Plate as a stencil to cut the fixing hole into the ceiling plate.

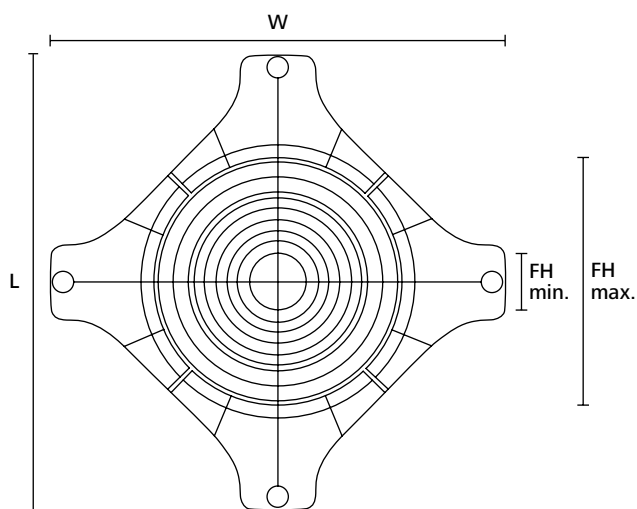

SpotClip-Plate

MATERIAL	Polyamide 6.6, heat stabilised (PA66HS)
Operating Temperature	-40 °C to +105 °C, (+105 °C for 500 h)
Flammability	UL 94 V2, Glow Wire Test (960 °C)



TYPE	Hole Ø (FH) min.	Hole Ø (FH) max.	Height (H)	Height (H2)	Length (L)	Width (W)	Colour	Pack Cont.	Article-No.
SpotClip-Plate 600	75.0	314.0	35.0	5.0	592.0	592.0	Black (BK)	10 pcs.	148-00117

All dimensions in mm. Subject to technical changes. Minimum Order Quantity (MOQ) may differ from package content.

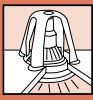

SpotClip-Plate - Further Accessories

SpotClip-Caps

SpotClip-Plate can be used to ensure the safety distance between the downlight and insulation material. We offer three different solutions to prevent damage to insulation material caused by overheating of the bulb.

1. Place two plates on top of each other and use IRL standard tubes between these to achieve the required distance
2. Use SpotClip-Caps and IRL standard tubes to achieve the required distance between the plate and insulation material
3. Combine SpotClip-Kit with SpotClip-Plate for a fast solution

Features and benefits

- Different solutions to ensure safety distance between downlight, damp-proof foil and insulation material
- SpotClip-Plate can be combined with SpotClip-Kit, SpotClip-Caps or placed on top of each other with standard SpotClip-Tubes to ensure the required distance
- Prevents damage to insulation material caused by overheating
- Improves life span and reliability of lamps
- Faster and easier installation and replacement of lamps



SpotClip-Caps offered in a pack of 40 pieces.



SpotClip-Plate combined with SpotClip-Caps.

MATERIAL	Polyamide 6.6, heat stabilised (PA66HS)
Operating Temperature	-40 °C to +105 °C, (+105 °C for 500 h)
Flammability	UL 94 V2, Glow Wire Test (960 °C)

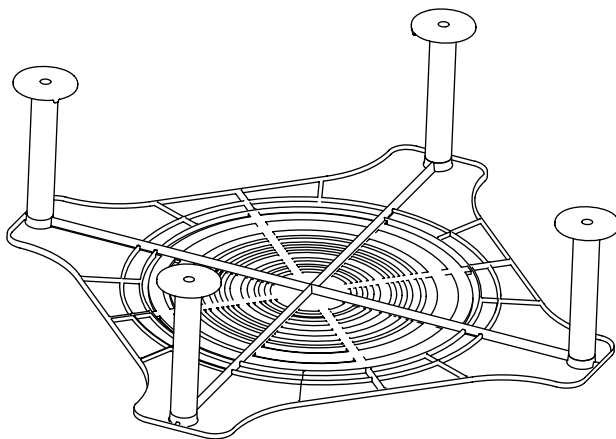

SpotClip-Plate in combination with IRL standard tubes and SpotClip-Caps

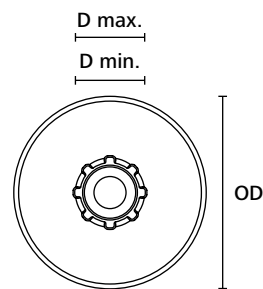

SpotClip-Cap

TYPE	Height (H)	Height (H2)	Outside Ø (OD)	Ø D min.	Ø D max.	Colour	Pack Cont.	Article-No.
SpotClip-Caps 16/25	30.0	25.0	60.0	16.0	22.0	Black (BK)	40 pcs.	148-00102

All dimensions in mm. Subject to technical changes. Minimum Order Quantity (MOQ) may differ from package content.



VarioPlate Cable Entry System

VarioPlate Frames

The VarioPlate Cable Entry System is used to install multiple cables of different diameters, with or without pre-terminated plugs or connectors, or wherever space is limited. It is available in 4 different frame sizes which correspond to the cut-out dimensions commonly used in panel building and for industrial machinery. Combinable grommets with 1, 2 or 4 holes, are available for cable diameters ranging from 3-16 mm (size S) and 16-33 mm (size L).

Features and benefits

- Time and space saving design
- Easy assembly, subsequent changes possible
- Wall gasket included in frame design
- Modular application for both insert sizes (S and L)
- Integrated strain relief
- Suitable for all common standard cut-out dimensions and drilling patterns
- Integrated cable diameter tolerance compensation
- For cut-out sizes up to 36 x 115 mm
- IP 65 and IP 66



MATERIAL	Polyamide 6.6, glass-fibre reinforced (PA66GF25)
Colour	Black (BK)
IP-Rating	IP66



TYPE	Drawing	Length (L)	Width (W)	Article-No.
VarioPlate-4_Frame		61.0	72.8	440-00000
VarioPlate-10_Frame		61.0	96.5	440-00001
VarioPlate-16_Frame		61.0	116.5	440-00002
VarioPlate-24_Frame		61.0	143.5	440-00003

All dimensions in mm. Subject to technical changes.



Please note: Some or all of the products listed here have these approvals, or have one or more sustainable attributes. Please see our website for the latest details.



VarioPlate Cable Entry System

VarioPlate Insert Grommets

VarioPlate cable entry system inserts grommets are used in combination with VarioPlate frames for time and space saving cable installation on all types of panel builder housings and control boxes. The versatile design covers cable diameter from 3 to 33mm. Inserts grommets are available in one, two, four holes and blindplugs.

Features and benefits

- Integrated cable diameter tolerance compensation
- Modular application for both insert sizes (S and L)
- Integrated strain relief
- IP 65 and IP 66



MATERIAL	Thermoplastic Elastomer (TPE)
Operating Temperature	-40 °C to +100 °C



TYPE	Drawing	Length (L)	Height (H)	Cable Ø min	Cable Ø max	Article-No.
VP-L_16-17_Ins-sgl		42.2	20.0	16.0	17.0	440-00024
VP-L_17-18_Ins-sgl		42.2	20.0	17.0	18.0	440-00025
VP-L_18-19_Ins-sgl		42.2	20.0	18.0	19.0	440-00026
VP-L_19-20_Ins-sgl		42.2	20.0	19.0	20.0	440-00027
VP-L_20-21_Ins-sgl		42.2	20.0	20.0	21.0	440-00028
VP-L_21-22_Ins-sgl		42.2	20.0	21.0	22.0	440-00029
VP-L_22-23_Ins-sgl		42.2	20.0	22.0	23.0	440-00030
VP-L_23-24_Ins-sgl		42.2	20.0	23.0	24.0	440-00031
VP-L_24-25_Ins-sgl		42.2	20.0	24.0	25.0	440-00032
VP-L_25-26_Ins-sgl		42.2	20.0	25.0	26.0	440-00033
VP-L_26-27_Ins-sgl		42.2	20.0	26.0	27.0	440-00034
VP-L_27-28_Ins-sgl		42.2	20.0	27.0	28.0	440-00035
VP-L_28-29_Ins-sgl		42.2	20.0	28.0	29.0	440-00036
VP-L_29-30_Ins-sgl		42.2	20.0	29.0	30.0	440-00037
VP-L_30-31_Ins-sgl		42.2	20.0	30.0	31.0	440-00038
VP-L_31-32_Ins-sgl		42.2	20.0	31.0	32.0	440-00039
VP-L_32-33_Ins-sgl	42.2	20.0	32.0	33.0	440-00040	

All dimensions in mm. Subject to technical changes.



Please note: Some or all of the products listed here have these approvals, or have one or more sustainable attributes. Please see our website for the latest details.



VarioPlate Cable Entry System

VarioPlate Insert Grommets

VarioPlate cable entry system inserts grommets are used in combination with VarioPlate frames for time and space saving cable installation on all types of panel builder housings and control boxes. The versatile design covers cable diameter from 3 to 33mm. Inserts grommets are available in one, two, four holes and blindplugs.

Features and benefits

- Integrated cable diameter tolerance compensation
- Modular application for both insert sizes (S and L)
- Integrated strain relief
- IP 65 and IP 66



MATERIAL	Thermoplastic Elastomer (TPE)
Operating Temperature	-40 °C to +100 °C



TYPE	Drawing	Length (L)	Height (H)	Cable Ø min	Cable Ø max	Article-No.
VP-S_0_Blindinsert		21.1	20.0	-	-	440-00004
VP-S_3-4_Ins-sgl		21.1	20.0	3.0	4.0	440-00005
VP-S_4-5_Ins-sgl		21.1	20.0	4.0	5.0	440-00006
VP-S_5-6_Ins-sgl		21.1	20.0	5.0	6.0	440-00007
VP-S_6-7_Ins-sgl		21.1	20.0	6.0	7.0	440-00008
VP-S_7-8_Ins-sgl		21.1	20.0	7.0	8.0	440-00009
VP-S_8-9_Ins-sgl		21.1	20.0	8.0	9.0	440-00010
VP-S_9-10_Ins-sgl		21.1	20.0	9.0	10.0	440-00011
VP-S_10-11_Ins-sgl		21.1	20.0	10.0	11.0	440-00012
VP-S_11-12_Ins-sgl		21.1	20.0	11.0	12.0	440-00013
VP-S_12-13_Ins-sgl		21.1	20.0	12.0	13.0	440-00014
VP-S_13-14_Ins-sgl		21.1	20.0	13.0	14.0	440-00015
VP-S_14-15_Ins-sgl		21.1	20.0	14.0	15.0	440-00016
VP-S_15-16_Ins-sgl		21.1	20.0	15.0	16.0	440-00017
VP-S_2/4-5_Ins-dbl			21.1	20.0	4.0	5.0
VP-S_2/5-6_Ins-dbl	21.1		20.0	5.0	6.0	440-00019
VP-S_2/6-7_Ins-dbl	21.1		20.0	6.0	7.0	440-00020
VP-S_2/7-8_Ins-dbl	21.1		20.0	7.0	8.0	440-00021
VP-S_4/4-5_Ins-quad		21.1	20.0	4.0	5.0	440-00022
VP-S_4/5-6_Ins-quad		21.1	20.0	5.0	6.0	440-00023

All dimensions in mm. Subject to technical changes.



Please note: Some or all of the products listed here have these approvals, or have one or more sustainable attributes. Please see our website for the latest details.



VarioPlate Cable Entry System

VarioPlate Blindplugs

VarioPlate cable entry system inserts grommets are used in combination with VarioPlate frames for time and space saving cable installation on all types of panel builder housings and control boxes. The versatile design covers cable diameter from 3 to 33mm. Inserts grommets are available in one, two, four holes and blindplugs.

MATERIAL	Plastic (PL)
Operating Temperature	-40 °C to +100 °C



Features and benefits

- Blind grommets are needed to replace the cable grommets that are not equipped with wires
- The IP protection class is retained

TYPE	Drawing	Ø (D)	Cable Ø min	Cable Ø max	Article-No.
VP_3-5_Blindplug		-	3.0	5.0	440-00041
VP_S_5_Blindplug		5.0	5.0	5.0	440-00049
VP_5-7_Blindplug		-	5.0	7.0	440-00042
VP_S_7_Blindplug		7.0	7.0	7.0	440-00050
VP_7-9_Blindplug		-	7.0	9.0	440-00043
VP_9-11_Blindplug		-	9.0	11.0	440-00044
VP_11-13_Blindplug		-	11.0	13.0	440-00045
VP_13-15_Blindplug		-	13.0	15.0	440-00046
VP_15-16_Blindplug		-	15.0	16.0	440-00047

All dimensions in mm. Subject to technical changes.



VarioPlate Cable Entry System

VarioPlate Mounting Tool

Features and benefits

- Assembly aid for VarioPlate
- Simple application



VarioPlate Mounting Tool.

MATERIAL	Polyamide 6.6, glass-fibre reinforced (PA66GF25)
Operating Temperature	-40 °C to +140 °C

HF ✓

RoHS ✓

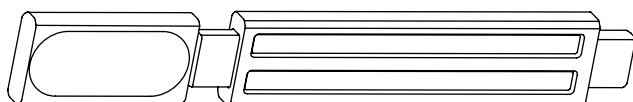

TYPE	Article-No.
VP_Mounting_Tool	440-00048

All dimensions in mm. Subject to technical changes.



Connection Products

Nylon Cable Glands

Nylon domed headed cable glands are quick and easy to install and cater for a wide range of cable sizes.

A range of quality nylon cable glands that can be used on a wide range of applications when connecting cable to electrical equipment (but not steel wire armoured cable).

Features and benefits

- Material Nylon 66
- Low smoke, zero halogen
- IP rating IP 68
- Metric thread
- available in red, black, white, grey, dark grey
- Complete with lock nut and washer
- Euro slot packaging



MATERIAL	Polyamide 6.6 (PA66)
IP-Rating	IP68



TYPE	Thread Size	Colour	Hole Ø (FH)	Pack Cont.	Article-No.
NGM12BK	M12	Black (BK)	3.0 - 6.5	10 pcs.	901-02000
NGM12DGY	M12	Dark Grey (DKGY)	3.0 - 6.5	10 pcs.	901-02001
NGM12GY	M12	Grey (GY)	3.0 - 6.5	10 pcs.	901-02002
NGM12RD	M12	Red (RD)	3.0 - 6.5	10 pcs.	901-02003
NGM12WE	M12	White (WH)	3.0 - 6.5	10 pcs.	901-02004
NGM16BK	M16	Black (BK)	5.0 - 10.0	10 pcs.	901-02005
NGM16DGY	M16	Dark Grey (DKGY)	5.0 - 10.0	10 pcs.	901-02006
NGM16GY	M16	Grey (GY)	5.0 - 10.0	10 pcs.	901-02007
NGM16RD	M16	Red (RD)	5.0 - 10.0	10 pcs.	901-02008
NGM16WE	M16	White (WH)	5.0 - 10.0	10 pcs.	901-02009
NGM20SBK	M20	Black (BK)	6.0 - 12.0	10 pcs.	901-02014
NGM20BK	M20	Black (BK)	10.0 - 14.0	10 pcs.	901-02010
NGM20SDGY	M20	Dark Grey (DKGY)	6.0 - 12.0	10 pcs.	901-02015
NGM20DGY	M20	Dark Grey (DKGY)	10.0 - 14.0	10 pcs.	901-02011
NGM20SGY	M20	Grey (GY)	6.0 - 12.0	10 pcs.	901-02016
NGM20GY	M20	Grey (GY)	10.0 - 14.0	10 pcs.	901-02012
NGM20SRD	M20	Red (RD)	6.0 - 12.0	10 pcs.	901-02017
NGM20RD	M20	Red (RD)	10.0 - 14.0	10 pcs.	901-02013
NGM20SWE	M20	White (WH)	6.0 - 12.0	10 pcs.	901-02018
NGM20WE	M20	White (WH)	10.0 - 14.0	10 pcs.	901-02019
NGM25BK	M25	Black (BK)	13.0 - 18.0	10 pcs.	901-02020
NGM25DGY	M25	Dark Grey (DKGY)	13.0 - 18.0	10 pcs.	901-02021
NGM25GY	M25	Grey (GY)	13.0 - 18.0	10 pcs.	901-02022
NGM25RD	M25	Red (RD)	13.0 - 18.0	10 pcs.	901-02023
NGM25WE	M25	White (WH)	13.0 - 18.0	10 pcs.	901-02024
NGM32BK	M32	Black (BK)	18.0 - 25.0	5 pcs.	901-02025
NGM32DGY	M32	Dark Grey (DKGY)	18.0 - 25.0	5 pcs.	901-02026
NGM32GY	M32	Grey (GY)	18.0 - 25.0	5 pcs.	901-02027
NGM32RD	M32	Red (RD)	18.0 - 25.0	5 pcs.	901-02028
NGM32WE	M32	White (WH)	18.0 - 25.0	5 pcs.	901-02029

All dimensions in mm. Subject to technical changes.



Connection Products

Nylon Cable Glands

TYPE	Thread Size	Colour	Hole Ø (FH)	Pack Cont.	Article-No.
NGM40BK	M40	Black (BK)	22.0 - 32.0	5 pcs.	901-02030
NGM40DGY	M40	Dark Grey (DKGY)	22.0 - 32.0	5 pcs.	901-02031
NGM40GY	M40	Grey (GY)	22.0 - 32.0	5 pcs.	901-02032
NGM40RD	M40	Red (RD)	22.0 - 32.0	5 pcs.	901-02033
NGM40WE	M40	White (WH)	22.0 - 32.0	5 pcs.	901-02034
NGM50BK	M50	Black (BK)	30.0 - 38.0	2 pcs.	901-02035
NGM50DGY	M50	Dark Grey (DKGY)	30.0 - 38.0	2 pcs.	901-02036
NGM50GY	M50	Grey (GY)	30.0 - 38.0	2 pcs.	901-02037
NGM50RD	M50	Red (RD)	30.0 - 38.0	2 pcs.	901-02038
NGM50WE	M50	White (WH)	30.0 - 38.0	2 pcs.	901-02039
NGM63BK	M63	Black (BK)	34.0 - 44.0	2 pcs.	901-02040
NGM63DGY	M63	Dark Grey (DKGY)	34.0 - 44.0	2 pcs.	901-02041
NGM63GY	M63	Grey (GY)	34.0 - 44.0	2 pcs.	901-02042
NGM63RD	M63	Red (RD)	34.0 - 44.0	2 pcs.	901-02043
NGM63WE	M63	White (WH)	34.0 - 44.0	2 pcs.	901-02044

All dimensions in mm. Subject to technical changes.